

**VOLTEX**<sup>®</sup>  
LIGHTING !!!

# Installation Guide

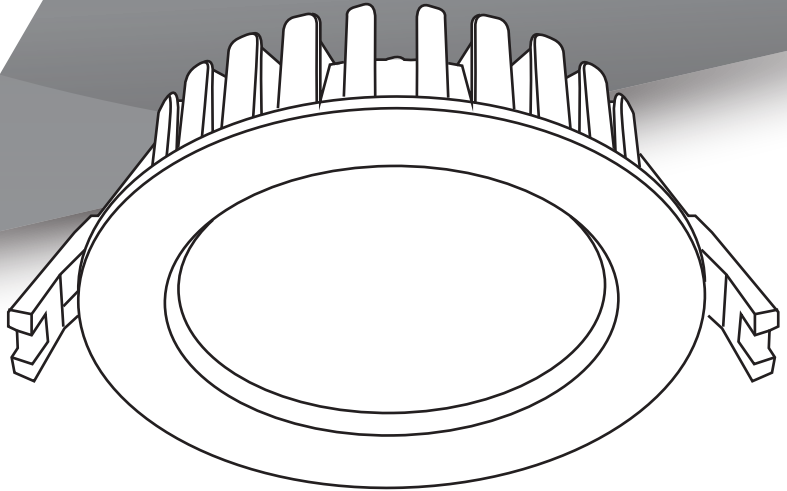

## Barcelona LED Downlight 13W

Warm White / Natural White / Cool White  
White / Silver



The Voltex® Barcelona 13W recessed LED downlight is truly a 'fit & forget' recessed luminaire, with no annoying bulb failures, while being highly energy-efficient and cool running for reduced fire risk. It is a sealed unit which has no air gap into the ceiling cavity, preventing the loss of conditioned air. This recessed downlight is guaranteed against premature failure of both the LED light engine and control gear for a period of 7 years from date of purchase. Original proof of purchase is required in the event of any guarantee claims being lodged.

## Specifications

Power	13W
Input Voltage	220-240V AC 50/60Hz
Driver	Dimmable - Trailing Edge
Class	IC-Abutted & Covered
Light Source	Epistar™
Light Colour	Warm White [3000K] / Cool White [6000K] / Natural White [4000K]
Luminous Flux	1100 Lumens [6000K] 1050 Lumens [4000K] 950 Lumens [3000K]
Ceiling Hole	90mm
Beam Angle	90 degrees
Air Transfer Category	Closed
Thermal Insulation Clearance	Side Abutted & Covered
Rated Lifespan	50,000 hours
Flange Colour	Matte/Silver
Connections	Includes Driver, Plug & Lead
Standards complied with	AS/NZS60598.1:2003 AS/NZS60598.2.2:2001 Including Amendment A
Side Clearance to Building Element (SCB)	0mm
Height Clearance to Building Element (HCB)	0mm

## Installation Instructions

1. Simply cut a 90mmØ hole in the ceiling, insert control gear and cable into the ceiling cavity and connect to the power supply by either of the following methods:
  - a. Plug into a pre-wired power outlet inside the ceiling [the luminaire comes complete with a moulded 2-pin plug]
  - b. Hardwire into junction box  
N.B. All installations of power outlets and/or junction boxes are to be carried out by a licensed electrician.
2. Then simply fold the spring clips up, insert the luminaire into the cut-out and it will clip itself snug against the ceiling.
3. Insulation may abut and cover the luminaire.
4. The independent lamp control gear must be mounted above the insulation and at least 600mm away from the luminaire and insulation [New Zealand Only]. See diagram below:

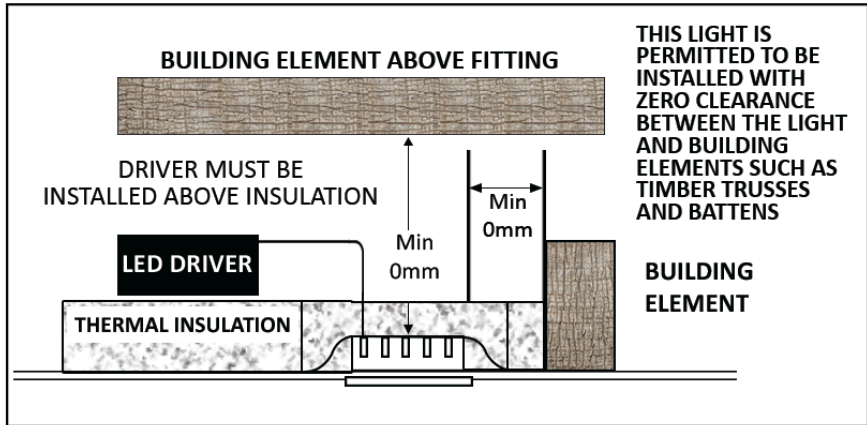

**RISK OF FIRE – Required clearance from structural members and building elements:**

Side clearance to building element (SCB): 0mm

Height clearance to building element (HCB): 0mm

**SPECIFIC REQUIREMENTS REGARDING BUILDING INSULATION:**

1. Building insulation abutting and/or within 100mm horizontally of the luminaire must meet the following requirements:
  - a. Be of a type that can maintain its dimensions and structural integrity when exposed to the maximum surface temperatures of the class of luminaire, being 90°C.
  - b. Be of a type able to withstand a 30 second needle flame test carried out in accordance with AS/NZS 60695.11.5 with the flame applied to all surfaces of the test sample.
2. Loose fill insulation as defined in NZS 4246 is not permitted to abut or cover this luminaire or be used anywhere near this downlight.
3. This luminaire is designed for indoor use only  $t_a=25^{\circ}\text{C}$ .